

Cone Crushers  
HP Series Cone Crushers





HP100

HP200

HP300

HP400

HP500

HP800



## High Performance for Higher Profitability

HP (High Performance) Series cone crushers feature a unique combination of crusher speed, throw, and cavity design. This combination has proved revolutionary in providing higher capacity and superior product quality, and in providing a wider range of application suitability. From limestone to taconite, from ballast production to manufactured sand, and from small portable plants, HP cone crushers provide unbeatable performance in secondary, tertiary, and quaternary applications.

### A history of quality

HP cone crushers are built on the success of our 70+ years of Symons cone experience, and 20+ years of Omnicone experience.

The Symons cone is well known for its rugged construction and application versatility. The Symons cone has set the standard in the mining industry, where 24-hour, high-reduction applications can destroy all but the most ruggedly built machine.

The Omnicone introduced many new innovations to reduce maintenance and operating costs, and to provide designed-in modern features such as hydraulic setting adjustment, tramp release, and cavity clearing.

The field-proven HP series combines the best of these technologies to provide the highest capacity, the best product shape, the highest on-spec yield, easy automation, and the greatest possible reliability and flexibility. All to help you achieve the highest possible levels of profitability.

For high productivity, low operating and wear costs, long service life, and high product yield with desired fines, there's no better choice than a cone crusher.

And Metso leads this market with its high-performance HP Series cone crushers for the aggregate and mining markets.



Mobile : The NW300HP is a highly mobile, closed-circuit crushing and screening plant. Ideal for contractors, it can transform your feed stock into three finished fractions.

# Reach New Heights with Metso

## Higher capacity

Thanks to the patented combination of higher speed and throw, which increases the machine's power rating and throughput capability, HP Series cone crushers have the highest capacities for their size in the industry.

HP technology allows you to use either fewer or smaller units to get the highest possible production out of the smallest possible space. Metso pioneered the HP technology, having developed it in 1989 through extensive pilot and full-size prototype testing. Metso has been awarded patents for these innovative efforts.



HP800 Cone Crusher.

## Higher quality

The unique interparticle crushing action of HP Series cone crushers creates a higher value for your product by providing a more consistent gradation and a superior product shape (cubicity). The ability to operate at a fixed mechanical setting – instead of the head floating on a column of hydraulic oil – creates less setting drift and provides more stability throughout the circuit. The proven benefit of a threaded rotating bowl maintains a consistent setting around the entire circumference of the crushing chamber. Also, the use of a tramp release system with a fixed return point makes sure that the crusher setting is instantaneously maintained even after passing a piece of tramp iron. HP Series cone crushers also enable you to produce a finer product with fewer crushing stages, lowering your capital costs and saving energy.

## Higher yield

By operating the HP cone crusher on the lower end of its speed range, the product gradation can be shifted to produce fewer fines and a higher percentage of on-spec product. The HP cone crusher creates a higher value product with less waste.



Stationary : One HP500, one HP300, two HP200 crushing "Amphibolite".





# Features and Benefits

### Less downtime

Dual-acting hydraulic tramp release cylinders mean the HP cone crushers can pass tramp iron that would stall many competitors' crushers. The large clearing stroke independent of liner wear reduces the effort required to clear a stalled crusher, reducing downtime and increasing operator confidence.

Hydraulic motors rotate the bowl for fine control setting adjustments that also rotate the bowl completely out of the adjustment ring threads for liner changeout, greatly simplifying liner change.

Advanced liner retention technology increase reliability: Bowl retaining wedges engage a self-tightening helix on the upper section of the bowl liner, while a self-tightening lock-bolt retains the mantle.

### Easy to maintain

Bronze bushings used throughout provide superior load capability in the high-shock, dusty crushing environment. They're low-cost, and easy to replace in the field with normal tools. HP cone crushers are easy to disassemble. All components are accessible from the top or the side. The head and bowl can be removed without upsetting a bolted interference fit.

### Low maintenance costs

High performance non-contacting labyrinth seals provide high reliability by keeping out dust without wearing out. Their simple design means fewer moving parts come into contact with the rock and dust.

Excellent wear protection of all crusher components – including replaceable head ball, mainframe seat liners, mainframe pin bushings, countershaft box frame ring, counterweight guard, mainframe liners, and the dead-bed feed hopper – keep maintenance costs to a minimum.

### Application flexibility

HP cone crushers can be converted from the finest to the coarsest cavity simply by replacing the mantle, bowl liner, adapter ring, and wedge bolts.

### Easy to operate

Using the hydraulic motor setting adjustment with the adjustment under load capability makes it easy to balance the crushing circuit and optimize crusher productivity. The addition of a hydraulic motor position transducer system to keep track of crusher setting is all that's required to connect the crusher to a plant DCS system for full automation applications.



Release system



Hydraulic adjustment



Liners fixing



Sealing system

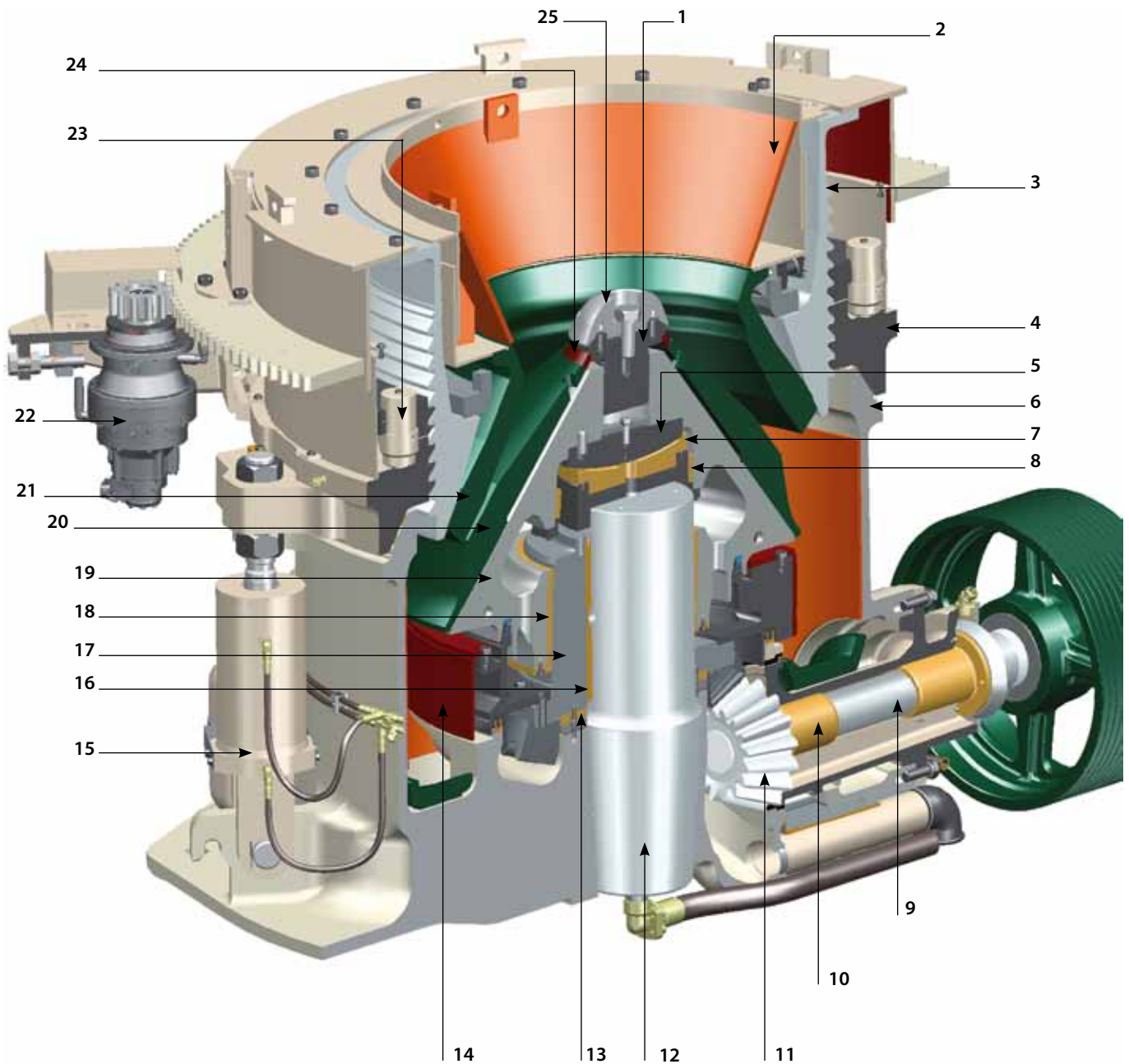

- |                        |                               |                                 |
|------------------------|-------------------------------|---------------------------------|
| 1 - Locking bolt       | 10 - Countershaft bushings    | 18 - Lower head bushing         |
| 2 - Feed bowl hopper   | 11 - Gear and pinion          | 19 - Head                       |
| 3 - Bowl               | 12 - Main shaft               | 20 - Mantle                     |
| 4 - Adjustment ring    | 13 - Eccentric thrust bearing | 21 - Bowl liner                 |
| 5 - Head bowl          | 14 - Counterweight guard      | 22 - Hydraulic adjustment motor |
| 6 - Main frame         | 15 - Tramp Release assembly   | 23 - Clamping cylinders         |
| 7 - Socket liner       | 16 - Eccentric bushing        | 24 - Torch ring                 |
| 8 - Upper head bushing | 17 - Eccentric                | 25 - Cone feed plate            |
| 9 - Countershaft       |                               |                                 |

**SPECIFICATIONS**



**Weights - Complete Crusher and Assemblies**

Size	HP100	HP200	HP300	HP400	HP500	HP800
Crusher Complete	5 400 kg 11 900 Lbs	10 400 kg 22 960 Lbs	15 810 kg 33 490 Lbs	23 000 kg 50 600 Lbs	33 150 kg 73 000 Lbs	68 650 kg 151 200 Lbs
Bowl, Bowl Liner, Adj. Cap, Hopper	1 320 kg 2 910 Lbs	2 680 kg 5 915 Lbs	3 525 kg 7 765 Lbs	4 800 kg 10 575 Lbs	7 200 kg 15 800 Lbs	17 350 kg 38 220 Lbs
Head Mantle and Feed Plate	600 kg 1 325 Lbs	1 200 kg 2 650 Lbs	2 060 kg 4 550 Lbs	3 240 kg 7 130 Lbs	5 120 kg 11 280 Lbs	10 800 kg 23 790 Lbs
Maximum recommended Power	90 kW 125 HP	132 kW 200 HP	200 kW 300 HP	315 kW 400 HP	355 kW 500 HP	600 kW 800 HP
Countershaft Speed-rpm	750-1200	750-1200	700-1200	700-1000	700-950	700-950

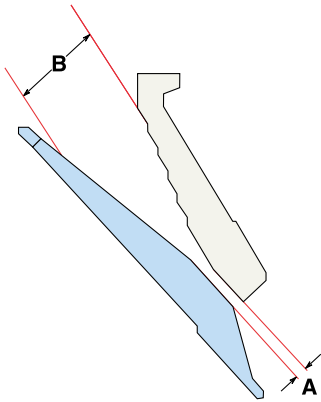

1 The minimum setting is that at which the crusher will operate without causing ring bounce. Depending on the crusher characteristics of the rock, this setting can change.

2 Feed opening "B" is at a minimum setting "A".

3 Maximum feed size vary from 80 to 100% of "B" depending on machine size and material.

**Crusher Cavity Selection**

Crusher size	Cavity	Standard		Short head	
		Minimum Setting "A"1	Feed Opening "B"2	Minimum Setting "A"1	Feed Opening "B"2
HP100	Extra Fine			6 mm (0.24")	14 mm (0.55")
	Fine			9 mm (0.35")	74 mm (2.91")
	Medium			9 mm (0.35")	72 mm (2.83")
	Coarse			13 mm (0.51")	100 mm (3.94")
	Extra Coarse			17 mm (0.67")	141 mm (5.55")
HP200	Extra Fine			6 mm (0.24")	10 mm (0.39")
	Fine	13 mm (0.52")	95 mm (3.74")	5 mm (0.20")	23 mm (0.90")
	Medium	17 mm (0.67")	125 mm (4.92")	6 mm (0.24")	54 mm (2.13")
	Coarse	19 mm (0.75")	185 mm (7.28")	10 mm (0.39")	76 mm (2.99")
	Extra Coarse				
HP300	Extra Fine			6 mm (0.24")	25 mm (0.98")
	Fine	13 mm (0.51")	107 mm (4.21")	6 mm (0.24")	22 mm (0.87")
	Medium	17 mm (0.67")	150 mm (5.91")	8 mm (0.31")	53 mm (2.09")
	Coarse	19 mm (0.75")	211 mm (8.31")	10 mm (0.39")	77 mm (3.03")
	Extra Coarse	25 mm (0.98")	233 mm (9.17")		
HP400	Extra Fine			6 mm (0.24")	52 mm (2.05")
	Fine	14 mm (0.55")	111 mm (4.37")	6 mm (0.24")	51 mm (2.00")
	Medium	20 mm (0.79")	198 mm (7.80")	8 mm (0.31")	52 mm (2.05")
	Coarse	25 mm (0.98")	252 mm (9.92")	10 mm (0.39")	92 mm (3.62")
	Extra Coarse	30 mm (1.18")	299 mm (11.77")		
HP500	Extra Fine			6 mm (0.24")	53 mm (2.09")
	Fine	16 mm (0.63")	133 mm (5.24")	8 mm (0.31")	52 mm (2.05")
	Medium	20 mm (0.79")	204 mm (8.03")	10 mm (0.39")	57 mm (2.24")
	Coarse	25 mm (0.98")	286 mm (11.26")	13 mm (0.51")	95 mm (3.74")
	Extra Coarse	30 mm (1.18")	335 mm (13.19")		
HP800	Extra Fine			5 mm (0.20")	33 mm (1.30")
	Fine	16 mm (0.63")	219 mm (8.62")	10 mm (0.39")	92 mm (3.62")
	Medium	25 mm (0.98")	267 mm (10.51")	13 mm (0.51")	155 mm (6.10")
	Coarse	32 mm (1.26")	297 mm (11.69")		
	Extra Coarse	32 mm (1.26")	353 mm (13.90")		

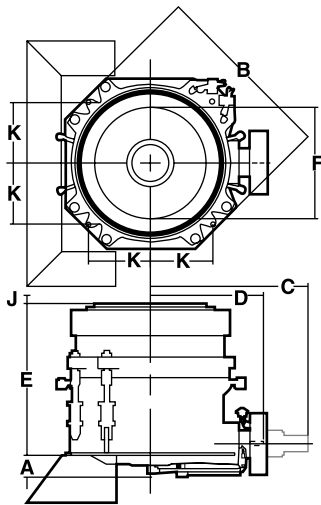

\* 5'1/2 - \*\*7'

Clearance dimensions						
Size	HP100	HP200	HP300	HP400	HP500	HP800
A - To bottom of oil piping	293 mm (11-9/16")	297 mm (11-11/16")	328 mm (12-15/16")	240 mm (9-1/2")	425 mm (16-3/4")	722 mm (28-7/16")
B - Adjustment ring maximum diameters	1 505 mm (59-1/4")	1 952 mm (76-7/8")	2 207 mm (86-7/8")	2 370 mm (93-3/8")	2 730 mm (107-1/2")	3 702 mm (145-3/4")
C - Clearance required for removing countershaft assembly	1 560 mm (61-7/16")	1 840 mm (72-7/16")	2 020 mm (79-1/2")	2 470 mm (97-1/4")	2 650 mm (104-3/8")	3 450 mm (135-13/16")
D - To end of countershaft	950 mm (37-3/8")	1 160 mm (45-11/16")	1 347 mm (53")	1 645 mm (64-3/4")	1 760 mm (69-1/4")	2 225 mm (85-5/8")
E - Maximum height to top	1 290 mm (50-13/16")	1 630 mm (64-3/4")	1 865 mm (73-7/16")	2 055 mm (80-7/8")	2 290 mm (90-1/8")	3 538 mm (139-1/4")
F - Inside diameter of feed hopper	694 mm (27-5/16")	914 mm (36")	1 078 mm (42-7/16")	1 308 mm (51-1/2")	1 535 mm (60-1/2")	1 863 mm (73-3/8")
Clearance required for removing bowl assembly	1 725 mm (67-15/16")	2 140 mm (84-1/4")	2 470 mm (97-1/4")	2 650 mm (104-3/8")	3 300 mm (29-7/8")	4 854 mm (191-1/8")
Clearance required for removing head assembly	1 700 mm (66-15/16")	2 165 mm (84-1/4")	2 455 mm (96-5/8")	2 715 mm (106-3/8")	3 165 mm (24-5/8")	4 634 mm (171-3/4")
J - Additional upward travel of feed hopper during clearing stroke	65 mm (2-9/16")	70 mm (2-3/4")	85 mm (3-3/8")	150 mm (4-1/8")	125 mm (4-15/16")	159 mm (6-1/4")
K - Mounting hole location	NA	545 mm (21-1/2")	660 mm (26")	830 mm (32-11/16")	882 mm (34-3/4")	1 130 mm* (44-1/2")* 1 245 mm** (49")**
Main frame discharge opening diameter	970 mm (38-3/16")	1 240 mm (48-13/16")	1 470 mm (57-7/8")	1 726 mm (68")	2 040 mm (80-1/2")	2 420 mm (95-1/4")

Product Gradation Table (% passing through square mesh depending on the setting)													
	6 (1/4")	8 (5/16")	10 (3/8")	13 (1/2")	16 (5/8")	19 (3/4")	22 (7/8")	25 (1")	28 (1-1/8")	32 (1-1/4")	38 (1-1/2")	45 (1-3/4")	51 (2")
100 (4")	100	100	100	100	100	100	100	100	100	100	100	100	100
75 (3")	100	100	100	100	100	100	100	100	100	100	100	100	98
63 (2-1/2")	100	100	100	100	100	100	100	100	100	100	99	95	90
51 (2")	100	100	100	100	100	100	100	100	99	98	92	82	68
38 (1-1/2")	100	100	100	100	100	100	100	98	95	90	76	62	50
32 (1-1/4")	100	100	100	100	100	100	95	90	79	69	52	42	36
25 (1")	100	100	100	100	98	94	85	74	60	49	40	33	28
22 (7/8")	100	100	100	100	95	88	76	63	51	42	34	28	25
19 (3/4")	100	100	100	98	92	82	68	57	46	37	30	26	22
16 (5/8")	100	100	99	92	80	69	55	46	36	29	24	20	18
13 (1/2")	100	99	92	78	66	55	43	36	28	22	18	16	14
10 (3/8")	100	93	81	66	55	45	34	30	23	18	15	13	11
8 (5/16")	94	82	69	55	45	37	28	24	19	15	13	11	10
6 (1/4")	82	67	55	43	36	29	22	19	16	12	9	8	7
4 (#5)	65	49	40	32	26	21	16	14	11	9	7	6	5
2 (#8)	40	28	23	17	13	11	8	7	6	4	3.5	3	2.5

**Crusher Capacities<sup>1</sup>**

Closed Setting													
Size	Tone/ hour	6 mm (1/4")	8 mm (5/16")	10 mm (3/8")	13 mm (1/2")	16 mm (5/8")	19 mm (3/4")	22 mm (7/8")	25 mm (1")	32 mm (1 1/4")	38 mm (1 1/2")	45 mm (1 3/4")	51 mm (2")
HP100	Mtph stph	45-55 50-60	50-60 55-65	55-70 60-75	60-80 65-90	70-90 80-100	75-95 85-105	80-100 85-110	85-110 95-120	100-140 110-155			
HP200	Mtph stph			90-120 100-130	120-150 130-165	140-180 155-200	150-190 165-210	160-200 175-220	170-220 185-240	190-235 210-260	210-250 230-275		
HP300	Mtph stph			115-140 125-155	150-185 165-205	180-220 200-240	200-240 220-265	220-260 240-285	230-280 255-310	250-320 275-355	300-380 330-420	350-440 385-485	
HP400	Mtph stph			140-175 155-195	185-230 205-255	225-280 250-310	255-320 280-355	275-345 305-380	295-370 325-410	325-430 360-475	360-490 395-545	410-560 450-625	465-630 510-700
HP500	Mtph stph			175-220 195-240	230-290 255-320	280-350 310-385	320-400 355-440	345-430 380-475	365-455 400-500	405-535 445-595	445-605 490-670	510-700 560-775	580-790 640-880
HP800	Mtph stph			260-335 285-370	325-425 360-470	385-500 425-550	435-545 480-600	470-600 520-660	495-730 545-805	545-800 600-880	600-950 690-1050	690-1050 760-1155	785-1200 865-1320

<sup>1</sup> Represents capacity through crusher based "instantaneous" product sample.

**Crusher Capacities**

Cone crusher capacity charts are developed for use as an application tool to properly utilize the HP crusher’s capabilities.

The capacity figures shown apply to material weighing 100 pounds per cubic foot or 1600 kg per cubic meter. The crusher is one component of the circuit. As such, its performance is in part dependent on the proper selection and operation of feeders, conveyors, screens, supporting structure, electric motors, drive component and surge bins. Where used, attention to the following factors will enhance crusher capacity and performance.

1. Proper selection of crushing chamber for material to be crushed.
2. A feed grading containing proper distribution of the particle size.
3. Controlled feed rate.
4. Proper feed distribution 360° around crushing chamber.
5. Discharge conveyor sized to carry maximum crusher capacity.
6. Properly sized scalping and closed circuit screens.
7. Automation controls.
8. Adequate crusher discharge area.

The following factors will detract from crusher capacity and performance.

1. Sticky material in crusher feed.

2. Fines in crusher feed (smaller than crusher setting) exceeding 10% of crusher capacity.
  3. Excessive feed moisture.
  4. Feed segregation in crusher cavity.
  5. Improper feed distribution around circumference of crusher cavity.
  6. Lack of feed control.
  7. Inefficient use of recommended connected horsepower.
  8. Insufficient conveyor capacity.
  9. Insufficient scalper and closed circuit screen capacities.
  10. Insufficient crusher discharge area.
  11. Extremely hard or tough material.
  12. Operation of crusher at less than recommended full load countershaft speed.
- For individual conditions, consult Metso.

**Gradation Curves\***

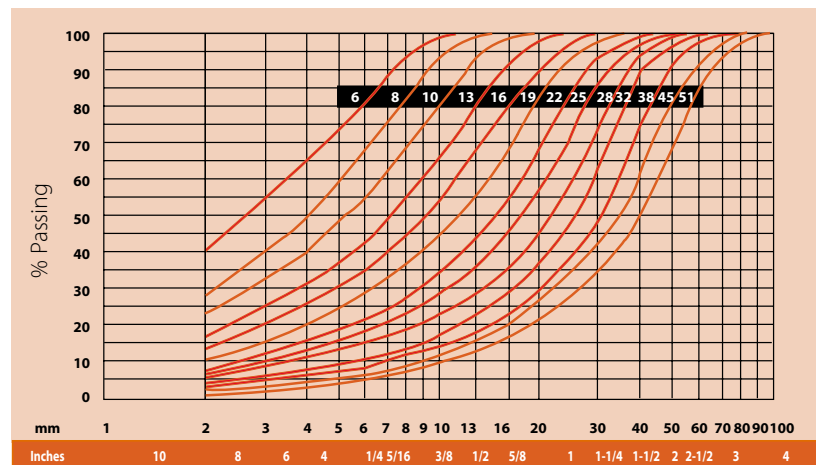

% passing through a square mesh depending on the setting

\* The gradation and capacities shown are dependent on the feed gradation, the crushing chamber, the material density, the material cleanliness, its moisture and its crushability.



**A world of difference**

Before, during and after the sale, you can count on the experts at Metso to provide the best service and support in the world – all over the world. Whether you’re installing an entire customized system, a complete circuit, or simply replacing or updating a single piece of equipment, you can count on us to help you make sure it’s the right equipment for your precise needs.

In the design stage, we look at variables such as ore characteristics and properties, physical space limitations, size of ore body – even your financial situation – just to name a few. Once you make your purchase, you’ll be linked to Metso’ on-line computerized parts availability system, giving you immediate access to the right parts, in stock, and delivered promptly. If

you have questions, a trained service analyst is always standing by – over the phone or in person – ready to analyze your needs and recommend a complete, long-term, cost-effective solution.

We even offer training schools to help you get the most out of your system. Over the years, thousands of crushing professionals like you have benefited from the wide variety of seminars we offer. Do you have special training needs? Tell us – and we’ll create a unique training session just for your company.

HP Series cone crushers. A world of difference in technology, quality, performance, reliability, and support. To find out more, contact your nearest Metso office.



## Metso Mining and Construction Technology crushing equipment

### Our Nordberg, Barmac and Lokotrack brand ranges:

#### Unit crushers

- C Series jaw crushers
- Primary gyratory crushers
- GP Series cone crushers
- HP Series cone crushers
- MP Series cone crushers
- NP Series horizontal impact crushers
- B Series vertical impact crushers
- Laboratory crushers

#### Mobile equipment

- LT Series mobile crushing plants
- NW Series portable plants

#### Complete plants

- Complete plants for aggregate production
- Complete plants for recycling

### Metso's Mining and Construction Technology main contacts

#### Australia and New Zealand

Metso Minerals (Australia) Ltd  
1110 Hay Street  
West Perth, WA 6005  
Australia  
Phone: +61 8 9420 5555  
Fax: +61 8 9320 2500

#### China

Metso Minerals (Beijing) Ltd  
19/F, The Exchange Beijing, Tower 4,  
China Merchants Centre,  
No. 118 Jian Guo Lu Yi Chaoyang District  
100022 Beijing,  
China  
Phone: +86 10 6566 6600  
Fax: +86 10 6566 2583

#### India and Asia-Pacific

Metso Minerals (India) Pvt Ltd  
1st Floor, DLF Building No. 10,  
Tower A, DLF Cybercity  
DLF Phase II,  
Gurgaon 122002  
India  
Phone: +91 124 235 1541  
Fax: +91 124 235 1601

#### Europe, Middle East and Africa

Metso Minerals España, S.A.  
C/ Rivas N° 4  
28032 Madrid  
Spain  
Phone: +34 91 825 5700  
Fax: +34 91 825 5740

#### North and Central America

Metso Minerals Industries Inc.  
20965 Crossroads Circle  
Waukesha, WI 53186  
U.S.A.  
Phone: +1 262 717 2500  
Fax: +1 262 717 2504

#### Russia and other CIS countries

ZAO Metso Minerals (CIS)  
V.O. Liniya, 70  
199178 St. Petersburg  
Russia  
Phone: +7 812 740 3040  
Fax: +7 812 740 5775

#### South America

Metso Minerals Indústria e Comércio Ltda  
Avenida Independência, 2500 - Éden  
18087-050 Sorocaba  
Brazil  
Phone: +55 15 2102 1300  
Fax: +55 15 2102 1696

#### Metso's Mining and Construction Technology

Lokomonkatu 3, P.O. Box 306  
33101 Tampere  
Finland  
Phone: +358 204 84 142  
Fax: +358 204 84 143

e-mail: [minerals.info.csr@metso.com](mailto:minerals.info.csr@metso.com)  
[www.metso.com/miningandconstruction](http://www.metso.com/miningandconstruction)

