

Metso

Combustion by design

KFS pyro and combustion solutions



The expertise, process and portfolio to get you results

A new division at Metso KFS brings over 20 years of delivering results for customers through superior combustion system design and processes.

Expertise

The Metso KFS product line has a distinct mastery of Computational Fluid Dynamics for burner design and system analysis backed up by an extensive history of physical modelling. This in-depth experience in modelling, simulation, interpretation and associated process engineering, coupled with an experienced and skilled staff, is used to supply an outstanding range of products and services to Process & Energy industries.

Process

Our purpose is to provide unique and innovative combustion solutions tailored to the specific needs of each customer, ensuring that their individual objectives are considered. To do so, every single project follows a tried and tested rigorous engineering approach, minimising risk at each stage.

Portfolio

In addition to a range of sophisticated burner products, the Metso KFS division is built of a team of experts who provide a comprehensive range of engineering services. Together, we can provide end-to-end solutions for your full combustion system.

Every solution we propose is truly custom. We take the time to learn and understand your specific operations, utilize proven analytical tools, and complete each model and design in-house, providing tailored burner designs to meet individual needs.

Metso KFS has a proven track-record for gas/liquid and solids fuels, including heavy fuel oil, natural gas, syn/biogas, H₂, tall oil, coal, petroleum, methanol, alternative fuels and biomass.

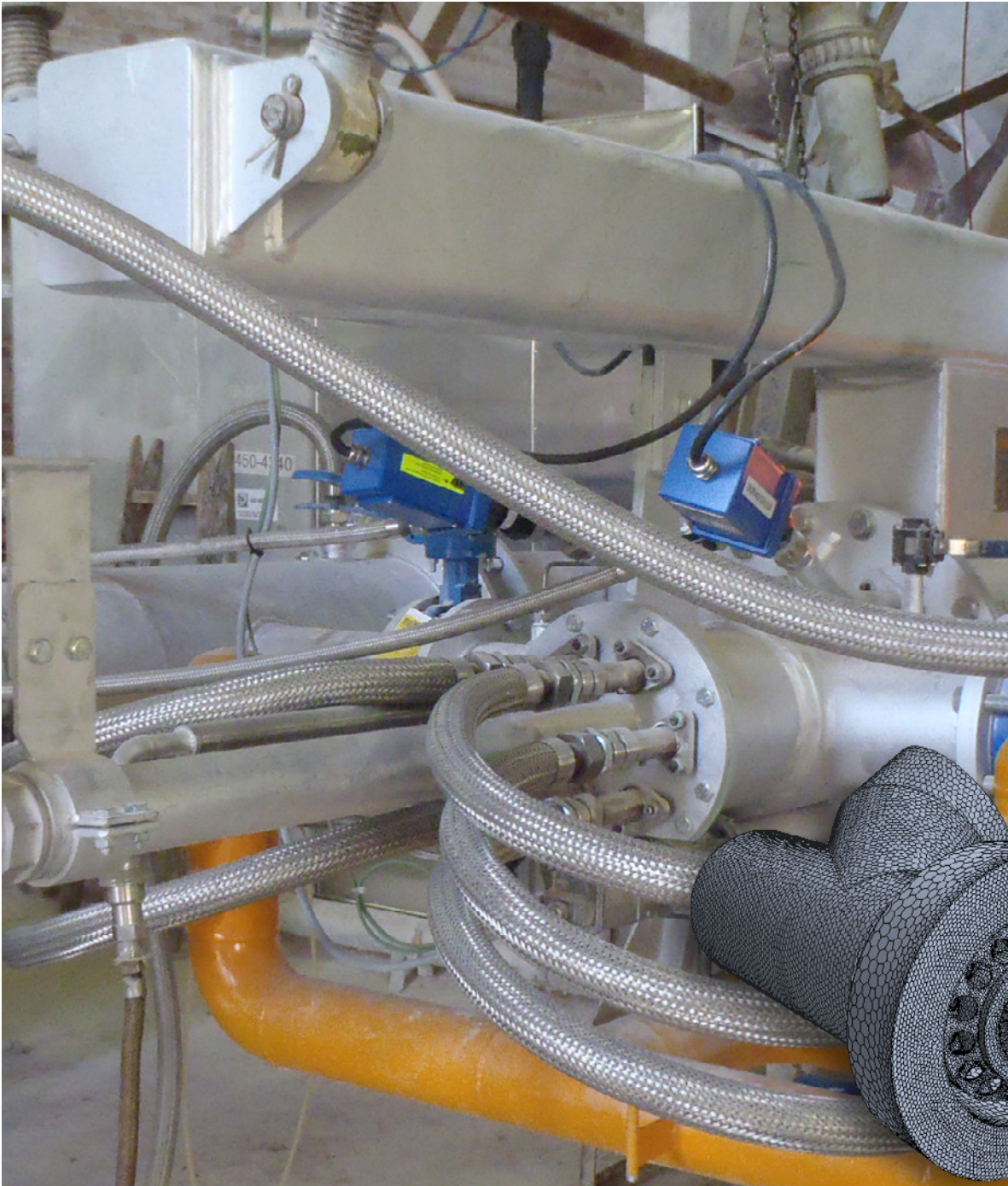

The results you can expect



Reduced production costs

- Lower fuel consumption
- Improved product quality
- Operation with lower cost fuels
- Reduced emissions



Long-term improved performance

- Robust designs and long service life
- Greater process up-time
- Reduced refractory damage
- Reduced formation of rings or build-up
- Increased process stability



Reduced risk

- Upfront, expert analysis
- Custom design providing the most reliable equipment
- Faster plant commissioning



Superior support when you need it

- Timely and high quality technical response
- Frequent monitoring of operation after start-up
- Regular on-going contact with operations
- Rapid provision of spare parts

A comprehensive offering of equipment and services

Combustion Equipment – Burners for Kilns and Pyro Processing Applications

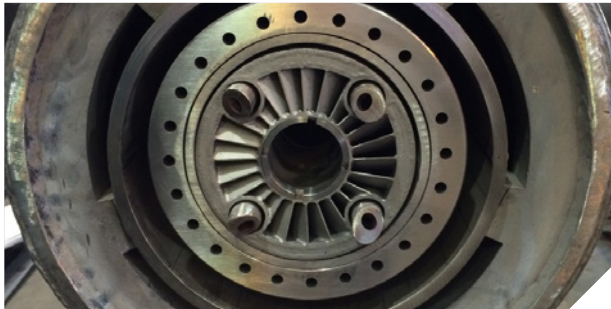

OptiMix™

A simple and elegant design that uses well established and proven changes in fuel/air mixing intensity to provide flame control. The primary air is split between axial air for flame length and heat flux control, and swirl air for flame anchoring. A highly efficient aerodynamic swirler provides excellent flame stability.

The OptiMix™ range is custom-designed for firing all fuel types, either individually or in combination. Each OptiMix™ burner is supplied with an integral pilot, including the extremely reliable natural gas or propane model.

Features

- Engineered to ensure consistent performance is available over the full equipment life
- Proprietary design avoids the complex mechanical adjustment mechanisms which are essential in most standard burners
- Avoids potential for local operations or maintenance to adjust incorrectly



Direct-Fired Nozzle (DFN)

Focused primarily in the lime and minerals industries, this advanced burner technology provides a straightforward retrofit to upgrade the performance of direct-fired systems or straight-pipe burners. High levels of performance are provided by careful use of bluff-body and swirl techniques to enhance fuel/air mixing combined with far greater flexibility than traditional straight-pipe.

The DFN range is custom-designed for firing all solid fuel types, as well as gas, liquid and alternative fuels.

Features

- Each DFN burner is custom-designed for the kiln both in terms of process performance and mechanical installation
- Developed using CFD modelling, the DFN burner has delivered outstanding improvements in areas such as production, fuel consumption, NOx emissions, and ash ring formation



HSB Warm-up Burners

The Metso KFS warm-up combustion system provides a safe and effective method to heat a rotary kiln from cold start through to main fuel firing.

A key to a safe kiln warm-up is the ability to provide a stable flame for an effective and controlled heat release profile. The HeatSafe Burner (HSB) design is based on our proven OptiMix™ integrated kiln burner design, which is in operation in over 100 rotary kilns.

Features

- Ideal for existing rotary kiln operations based on straight pipe burner technology
- A proprietary design fuel nozzle provides a dependable source of ignition, plus a high efficiency air swirler for easy light-off and a stable flame under variable kiln conditions

Ancillary Equipment

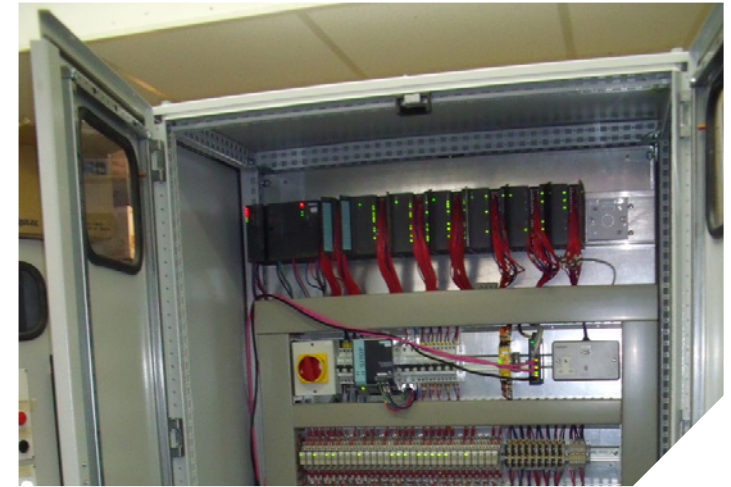

As part of system design, Metso offers a number of ancillary items which enhance or complete the combustion system.

Fuel Handling	Valve trains for all gaseous and liquid fuels, and solid fuel storage and feed systems, all in accordance with customer and local specifications, while meeting appropriate national and regional standards.
NCG Lances	Custom-designed to handle single or multiple streams (SOG, HVLC, LVHC, etc.) to minimise impact on the main burner and kiln.
Primary Air Systems	Fans and associated equipment with flow-meters to accurately and reliably monitor primary air flowrates, which are essential in maintaining optimum combustion performance.
Flame Scanners	Use of state-of-the-art ultra-violet (UV) and infra-red (IR) systems.
Burner Management Systems	Provision of PLC-based systems for single and multi-fuel applications in compliance with North American, European or other national standards.
Ignitor Systems	Natural or propane gas pilots for continuous or intermittent use, high-energy ignitors with automatic retraction system operation.
Selective Non-Catalytic Reduction (SNCR)	Design and supply of SNCR systems for installation on combustion systems to reduce NO _x emissions, utilising our in-house CFD modelling capability to optimise injection lance arrangements.

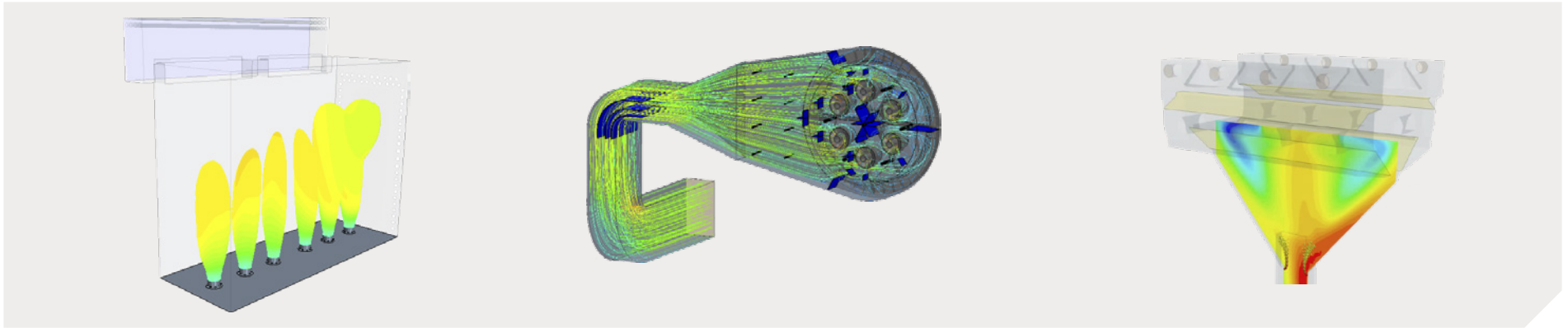

Computational Fluid Dynamics (CFD) Modelling

CFD is an integral part of our design process for combustion systems. Whether as a stand-alone consultancy service or a part of our standard combustion offering, CFD allows for detailed examination of flame and temperature profiles, as well as their impact on process conditions and emissions.

Rotary Kiln – Lime and Cement

Metso KFS has developed a proprietary lime bed chemistry module to be fully coupled with CFD. This has been extended to cement bed chemistry which is more complex and involves multiple reactions for clinker formation.

Rotary Kiln – Pulp & Paper, LWA, Clay, etc.

From material feed through combustion, processing and material discharge, we have used CFD extensively to help understand the process and provide guidance on the design of combustion equipment and the kiln itself.

SNCR – Various Industries

Metso KFS uses CFD during the system design stage to optimise the injector location to maximise NO_x reduction while avoiding ammonia slippage.

Fired Heaters and Boilers – Oil & Gas

CFD is used for simulating combustion in fired heaters, boilers and furnaces including prediction of NO_x emissions and assessment of heat flux to, and surface temperature of the process tubes.

Burner Internal Flows – Solid Fuel Analysis

CFD is an indispensable tool in solid fuel firing (coal, petcoke or biomass), where the life of the burner components greatly depends on the impact of particles on the surface of the material use.

Preheaters and Calciners – Lime and Alumina

Modelling these systems are used not only to optimise system performance but also to reduce NO_x emissions and operating issues such as refractory damage and material build-up.

Process Dryers – Food Processing and Chemical

CFD can also be used for flash dryers, classifiers, cyclones and bag filters, where specified flow patterns and solid particle size distributions are desirable.

Sintering and Pelletizing - Ferrous and Metals

Combining the process knowledge of Metso and Outotec with the combustion knowledge of Metso KFS, CFD can be used to optimise the system design to improve production, efficiency and product quality for grate kiln and straight / travelling grate sintering and pelletizing plants.



Engineering Services

Metso offers a comprehensive range of engineering services to enhance and complement core products. Using our solution-based approach, we can provide a total lifecycle offering.

Plant Safety Studies

Safety should be the basis of any combustion system design. Ageing systems are often not in compliance with current safety standards, putting personnel and equipment at risk.

Combustion System Optimisation Studies

Achieving maximum production and minimising fuel consumption is the goal of every operator. Using our unique rotary kiln database in conjunction with CFD modelling, we can benchmark your rotary kiln against hundreds of similar kilns.

Mechanical and Electrical Design Services

The success of every project requires thorough and rigorous planning to ensure a comprehensive design process and successful implementation. We can offer cost-effective design services, allowing end users and operators to focus on running the plant.

Project Management

With reduced numbers of operating staff at sites we can take the strain to deliver projects economically and on time to meet your shutdown.

Site Services

Driven to provide unrivalled customer support, Metso KFS offers a comprehensive package of site services to support our customers and help maximise production and product quality.

- Training for operators and process engineers
- Burner tuning and maintenance
- Spare parts
- Service agreements

How we work together

To minimise risk at each stage, as well as ensure collaboration and alignment, every Metso project follows our tried and tested rigorous engineering approach.

1. Site Survey

- Evaluation and benchmarking of process combustion
- Review of existing systems and equipment
- Detailed combustion analysis

2. Modelling

- Assess current operating conditions
- Aerodynamic and combustion modelling
- Computational Fluid Dynamics (CFD) or physical modelling of burner system design parameters
- Optimisation of systems

3. Detailed Design, Manufacture and Supply

- Equipment detailed design
- Layout and detailed design using 3D modelling
- Combustion system PFD & P&ID
- System integration
- Fuel system design
- Burner Management System functional design specification
- Certification
- I, O & M manuals

4. Installation, Commissioning and Training

- Supervision of installation
- Turnkey installation
- Comprehensive operator training
- Cold and hot commissioning
- Optimisation of burner operation

5. Follow-up, Spare Parts and Service

- Active follow-up of installations
- Provision of spare parts
- Service of supplied equipment

1.



2.

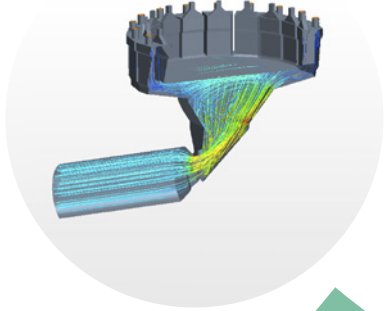

5.

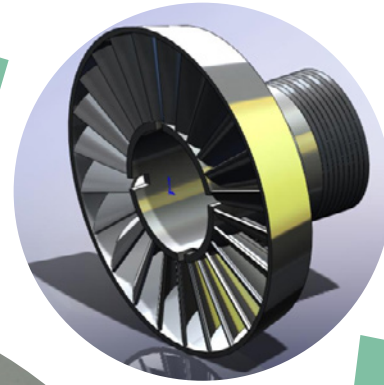

4.



3.



Expertise across industries

Metso has a history of servicing process and energy sectors, cutting across a multitude of industries. We continue to work with equipment end-user/operators, manufacturers and engineering integrators. With a global network of experience, we have a proven track record in delivering improved performance across numerous types of applications.



Pulp & Paper

As a world-leading supplier of lime recovery kiln burners and fuel delivery systems to the pulp and paper industry, our burner retrofits and upgrades improve kiln performance and operation.



Lime

With an in-depth understanding of the process for preheater and long kilns, Metso KFS has had successful installations of rotary kiln burners at major lime companies across North America and Europe.



Alumina

Our offering includes system modelling and combustion equipment design for alumina flash calciner, fluid bed, and rotary kiln systems for both oil and natural gas.



Metals Processing

We have experience working with the processing of ores in rotary kilns for nickel, iron ore, antimony, zinc and lithium.



Oil & Gas

Given the industry's need for a better understanding of the fluid dynamics involved in combustion systems, we have developed our CFD modelling capability to include multiburner



Cement

Metso KFS kiln burner designs combined with our unique cement kiln CFD modelling and experience in solid fuel combustion can help optimise cement kiln production.



Petcoke Calcining

Combining Metso expertise and technologies with the KFS combustion expertise provides the customer with world leading petcoke calcining systems



LWA & Minerals

Metso has designed and supplied the specialist combustion systems for manufacturing low density aggregates.



Ferrous

Offering latest combustion technologies to compliment and enhance the operation for grate kiln and straight (travelling) grate pelletizing plants

One piece of Metso's full pyro portfolio

Combustion solutions is just one piece of what we can truly offer. From hard-working reliable equipment to a comprehensive service offering, Metso can help you achieve optimal performance in your pyro processing operations. Specialising in pelletization, calcining, and incineration, we have developed the expertise and flexibility to provide customized solutions for your specific goals.



Spare parts supply

OEM parts available for a variety of brands, all held to stringent quality standards

- Reliable original parts that work with no fuss
- Tried, tested and available



Upgrade, retrofits and repairs

A range of possibilities, from small tyre crack repairs to a shell section replacement to a complete overhaul

- Extend the life of your equipment
- Achieve performance improvements: profitability, uptime, safety



Inspection and alignment services

Regular maintenance is a core practice that should not be overlooked

- Variety of standardised inspection packages
- Comprehensive alignment services can be performed during normal operations



Training and seminars

An extensive array of training programs designed for real world operations

- Specialised in hands-on training for operators and maintenance
- Offering on-site training and regional seminars

- Allis-Chalmers
- Allis Mineral Systems
- Boliden Allis
- Joy Incineration
- Kennedy Van Saun (KVS)
- MPSI/Hardinge
- Marconaflo/Dynajet
- Mine & Smelter
- Pyrotherm
- Stansteel
- Kiln Flame Systems (KFS)

Metso is a frontrunner in providing sustainable technologies, end-to-end solutions and services for the aggregates, minerals processing and metals refining industries globally. By helping our customers increase their productivity, improve their energy and water efficiency and environmental performance with our process and product expertise, we are the **partner for positive change**.

[metso.com](https://www.metso.com)

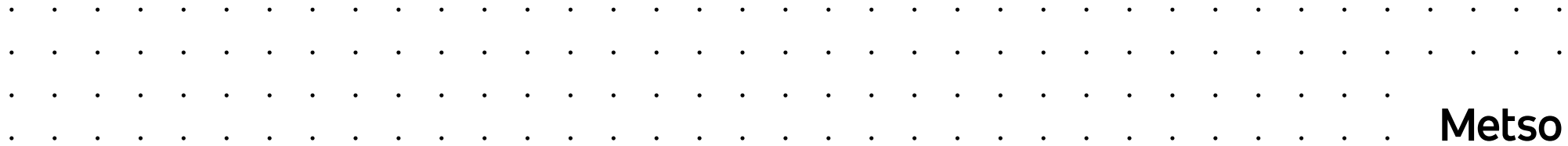

Metso