

Metso:Outotec

Nordberg GP series cone crushers

Wear parts application guide

Application guide

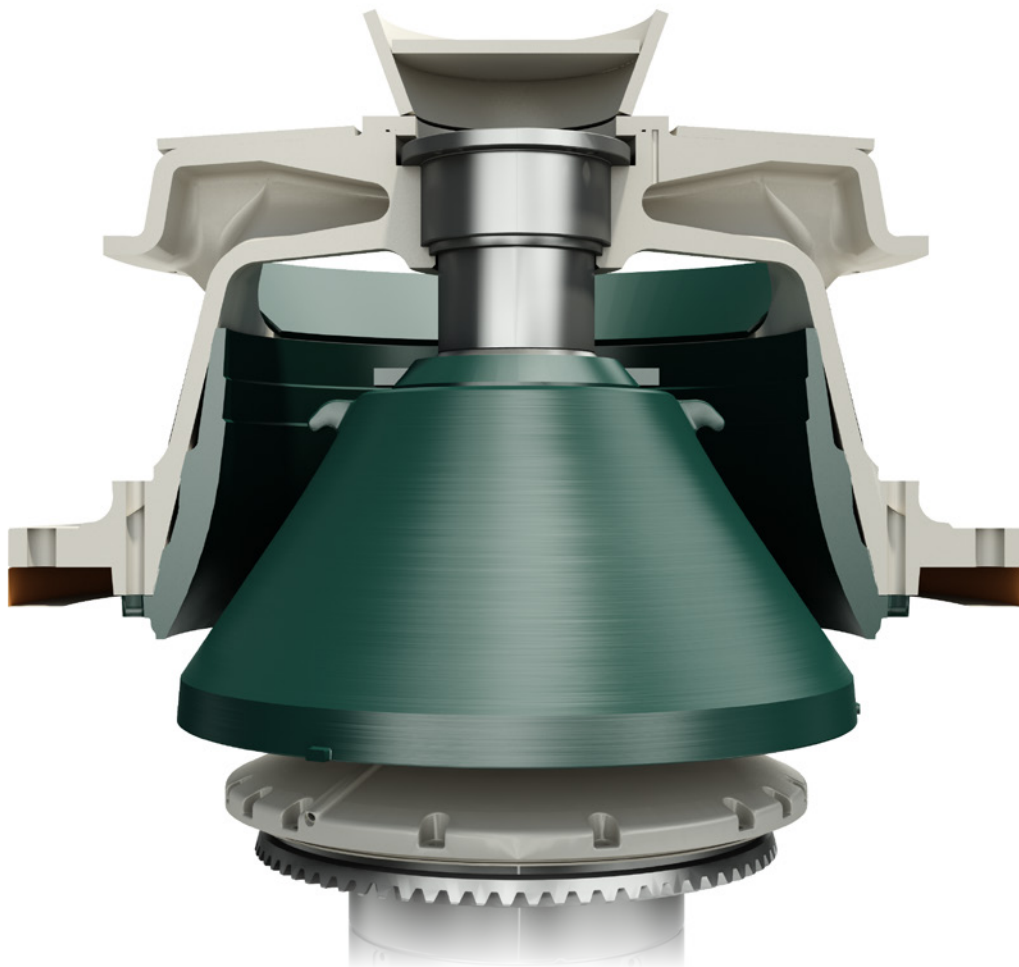

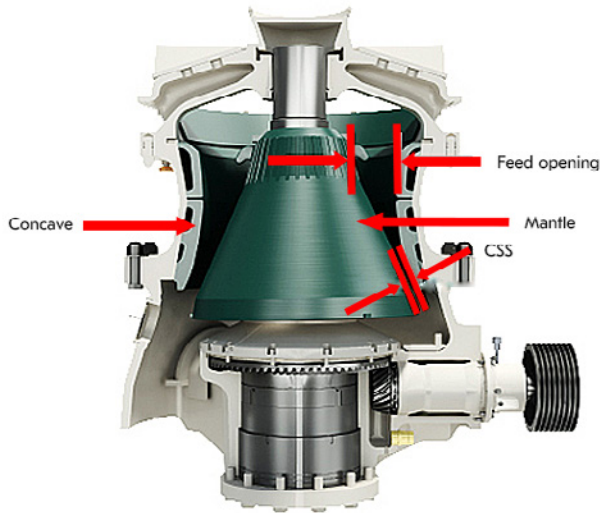

Wear parts application guide - Nordberg GP series cone crusher

GP cone crusher and basic concepts

GP cone crusher is a compressive crusher where feed material is crushed between a fixed concave and a movable mantle. Bigger rock particles are crushed against the mantle and concave. This is called single-layer crushing. Smaller rock particles are crushed between other rock particles, which is called multi-layer crushing. Multi-layer crushing plays a significant role in the GP cavity. This improves the end product shape and reduces wear in wear parts.

Nip angle

The nip angle is the the angle between the mantle and the concave. Too large nip angle reduces the capacity and increases the wear due to feed material is bouncing upwards in the cavity.

Reduction ratio

The reduction ratio means the reduction factor between feed and a product. This ratio is usually taken from the 80% point of the feed and product curve. A typical reduction ratio for the GP secondary crusher is 3-5 and, for the GP fine crusher, 1.5-3.

Feed opening

The feed opening defines the maximum feed size to the crusher. In GP cone, the closed side feed opening is measured from the top of the concave to the top of the mantle when the mantle is at the closed side setting position.

The maximum feed size in GP cone is the same as closed side feed opening. Maximum feed sizes are also stated in cavity configuration tables later in the guide.

Closed side setting (CSS)

The closed side setting defines the reduction ratio in GP cone crusher and has significant bearing on product gradation, capacity and power draw.

The closed side setting is measured from the bottom of the mantle to the bottom of the concave at their closest coincidence during the gyrating cycle.

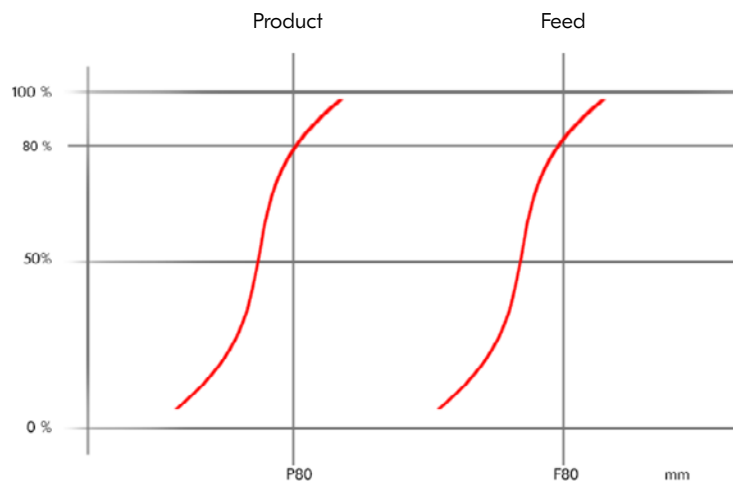

$$\text{Reduction ratio} = F80 / P80$$



How to operate a GP cone crusher

In order to get optimum capacity and maximum lifetime of wear parts, consider the following points:

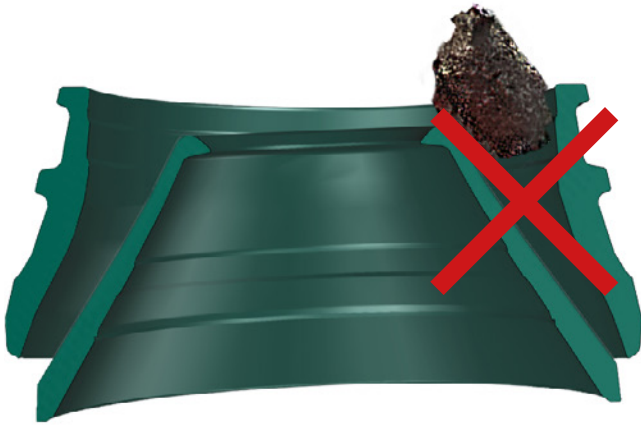

Too big feed material

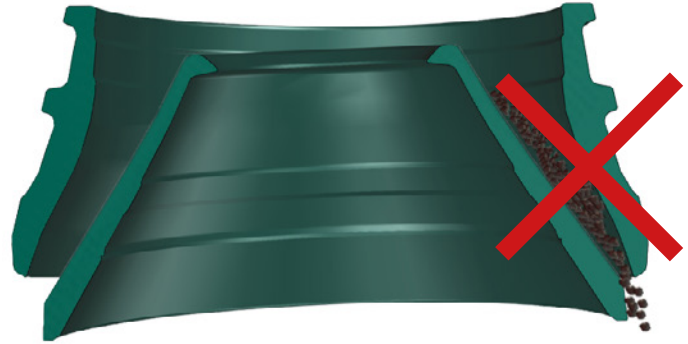

Too small feed material

1. Check the feed arrangement:

- The crusher should be choke fed so that the crushing chamber is full all the time. This is important, especially in fine crushing. Choke feeding maximizes the amount of multi-layer crushing, and improves wear shape and crushing efficiency.
 1. Choke feed level for GP secondary crusher is at the level of the mantle fixing nut
 2. Choke feed level for GP fine crusher is max 1 meter above the top bearing arrangement
- The feed must be distributed evenly 360° across the crushing chamber. Uneven feed distribution may cause unbalanced crushing forces and uneven wearing in the GP concave.
- Feed should not be segregated (for example finer material in other side of cavity).
- The flow of the feed should be stable and continuous. (However GP cone crusher can be used in pulse fed applications as the head spin is minimized.)
- Circulation is needed when producing high quality products.

2. Check the feed size and gradation:

- Oversize feed material decreases capacity and can cause unnecessary loads to the crusher.
- Too small feed size for the cavity increases wearing at the bottom part of liners and may cause poor utilization rate of wear parts.
- Fines (0-4) should be screened away before the crusher as they may cause packing. (GP secondary is not sensitive to fines)
- Feed gradation should be stable (no gaps in feed).

Note: Feed material characteristics such as gradation, bulk density, moisture, clay content and crushability have significant impact on crusher capacity.



Good feed level and distribution



| | Feed material characteristics | | | Operating parameters | | |
|------------------------------|-------------------------------|-----------------------|-----------------|----------------------|----------------|------------|
| | Easy crushability | High specific gravity | Stroke increase | Setting increase | Speed increase | Choke feed |
| Shape of < C.S.S. in product | ↑ | | ↑ | | ↑ | ↑ |
| Capacity | | ↑ | ↑ | ↑ | | ↑ |
| Cubicity of product | ↑ | | ↑ | | ↑ | ↑ |
| Power consumption | | | ↑ | ↓ | | ↑ |
| Energy consumption kWh/ton | | ↓ | ↓ | ↓ | | ↑ |

Indicative table

3. Check the setting. It should be close to required product

- Setting increases -> Product size increases
- Setting increases -> Capacity increases
- Setting increases -> Power draw decreases

4. Check the stroke

- Stroke increases -> Capacity increases
- Stroke increases -> Power draw increases

5. Check the cavity in use

- Based on feed size
- Based on required end product size which gives required setting range
- Check the crushing ratio.

6. Check the wear profile of the liners: A distorted wear profile may decrease capacity, increase wearing and increase crushing forces

Example of bad wearing. Cupping has occurred.



Example of normal wear. Obtained with correct feed arrangements, feed gradation and parameters for the cavity.



GP secondary cone crusher cavity selection

Each GP secondary cone crusher has two cavity options with different feed openings and setting ranges. The correct cavity can be selected based on feed size and setting.

| GP Secondary | Difficult and abrasive rock | Difficult and non abrasive rock | Medium and abrasive rock | Medium and non abrasive rock | Easy and abrasive rock | Easy and non abrasive rock |
|---------------|-----------------------------|---------------------------------|--------------------------|------------------------------|------------------------|----------------------------|
| XT510 / XT610 | | | | ●●● | ●● | ●●● |
| XT710 | ●●● | ●●● | ●●● | ●●● | ●●● | ●●● |
| XT720 / XT810 | ●●● | ●● | ●●● | | ●● | |

● Can be used ●● Good choice ●●● Recommended Definitions for different rock types are presented in Wear and materials application guide, page 4.

The minimum setting is limited by either the power requirement or adjusting pressure. Depending on rock characteristics, the minimum closed side setting can change.

Maximum feed size and setting ranges min-max, mm (in)

| | GP100S | | GP200S | | GP300S | | GP500S | | GP7 | | |
|-------------------------|----------------------|----------------------|------------------------|------------------------|----------------------|----------------------|----------------------|----------------------|----------------------|----------------------|-----------------------|
| | M | C | C | EC | C | EC | C | EC | C | EC | EC-TR |
| Max Feed size | 199 (7.83) | 236 (9.29) | 212 (8.35) | 286 (11.3) | 237 (9.33) | 320 (12.6) | 340 (13.4) | 392 (15.43) | 324 (12.76) | 403 (15.87) | 403 (15.87) |
| 16 mm (0.63 in) stroke | 20-43 (0.79-1.69) | 24-48 (0.94-1.89) | | | | | | | | | |
| 18 mm (0.71 in) stroke | | | 24-46 (0.94-1.81) | 26-52 (1.02-2.05) | 25-47 (0.98-1.85) | 28-53 (1.10-2.09) | 30-67 (1.18-2.64) | 35-77 (1.38-3.03) | | | |
| 20 mm (0.79 in) stroke | 24-41 (0.94-1.61) | 29-46 (1.14-1.81) | | | | | | | | | |
| 25 mm (0.98 in) stroke | 28-39 (1.10-1.54) | 34-44 (1.34-1.73) | 27-43 (1.06-1.69) | 29-49 (1.14-1.93) | 29-44 (1.14-1.73) | 32-50 (1.26-1.97) | 35-63 (1.38-2.48) | 40-74 (1.57-2.91) | 27-82 (1.06-3.23) | 34-93 (1.34-3.66) | 34-139 (1.34-5.47) |
| 28 mm (1.10 in) stroke | | | 28.5-41 (1.12-1.61) | 30.5-47 (1.20-1.85) | 31-42 (1.22-1.65) | 34-48 (1.34-1.89) | 37-62 (1.46-2.44) | 42-72 (1.65-2.83) | 28-80 (1.10-3.15) | 32-92 (1.26-3.62) | 36-138 (1.42-5.43) |
| 32 mm (1.26 in) stroke | | | 30-39 (1.18-1.54) | 32-45 (1.26-1.77) | 33-40 (1.30-1.57) | 36-46 (1.42-1.81) | 40-60 (1.57-2.36) | 45-70 (1.77-2.76) | 30-78 (1.18-3.07) | 38-90 (1.50-3.54) | 38-136 (1.50-5.35) |
| 36 mm (1.42 in) stroke | | | 31.5-37 (1.24-1.46) | 33.5-43 (1.32-1.69) | 35-38 (1.38-1.5) | 38-44 (1.5-1.73) | 43-57 (1.69-2.24) | 48-67 (1.89-2.64) | 32-76 (1.26-2.99) | 40-88 (1.57-3.46) | 40-134 (1.57-5.28) |
| 40 mm (1.57 in) stroke | | | | | | | 45-55 (1.77-2.17) | 50-65 (1.97-2.56) | 34-74 (1.34-2.91) | 43-86 (1.69-3.39) | 43-132 (1.69-5.20) |
| 45 mm (1.77 in) stroke | | | | | | | | | 36-72 (1.42-2.83) | 45-83 (1.77-3.27) | 45-129 (1.77-5.08) |
| 50 mm (1.97 in) stroke | | | | | | | | | 36-69 (1.54-2.72) | 48-81 (1.89-3.19) | 48-126 (1.89-4.96) |

M = Medium C = Coarse EC = Extra coarse ECTR = Extra coarse - tramp release

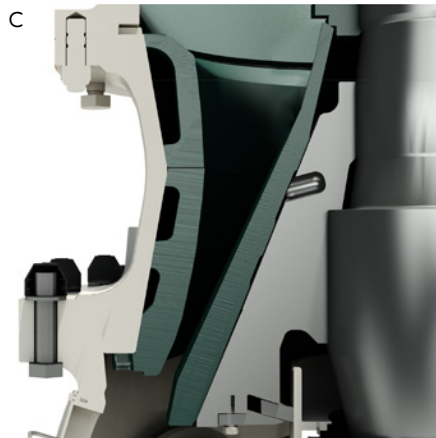

GP100S M / GP200S C / GP300S C / GP500S C / GP7 C

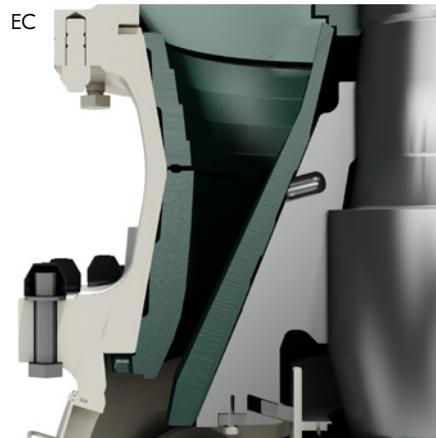

GP100S EC / GP200S EC / GP300S EC / GP500S EC / GP7 EC





GP fine cone crusher cavity selection

Each GP fine cone crusher has several cavity options with different feed openings and setting ranges.

The correct cavity can be selected based on feed size and setting.

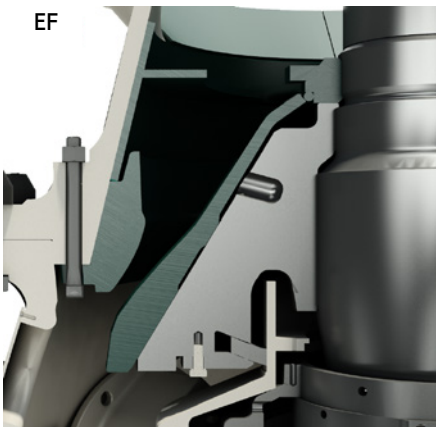

GP100 EF, GP11F EF, GP200 EF, GP220 EF, GP300 EF, GP330 EF, GP550 EF

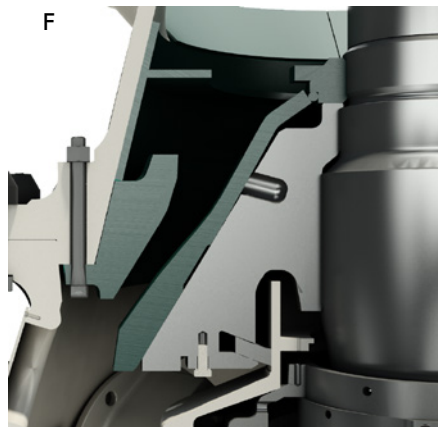

GP100 F, GP11F F, GP200 F, GP220 F, GP300 F, GP330 F, GP550 F

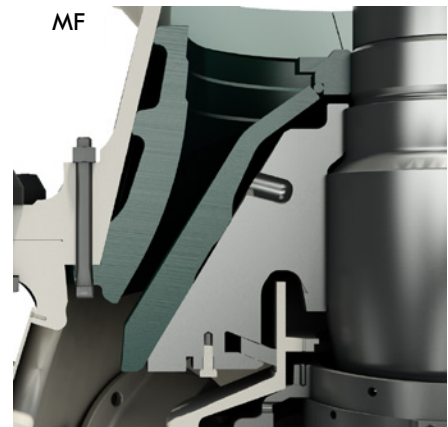

GP100 MF, GP220 MF, GP300 MF, GP330 MF, GP550 MF

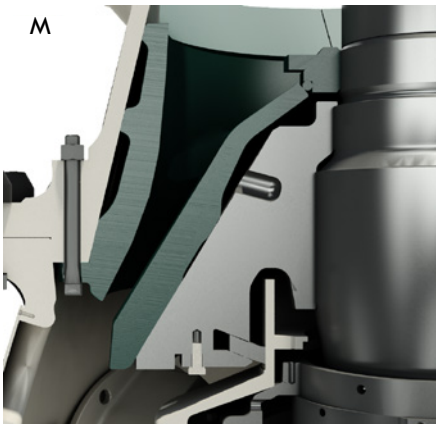

GP100 M, GP11F M, GP200 M, GP220 M, GP300 M, GP330 M, GP550 M

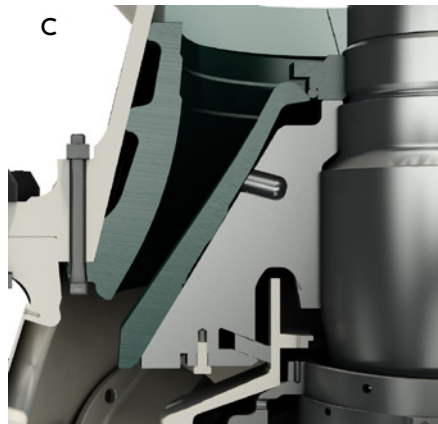

GP100 C, GP11F C, GP11M C, GP200 C, GP220 C, GP300 C, GP330 C, GP550 C

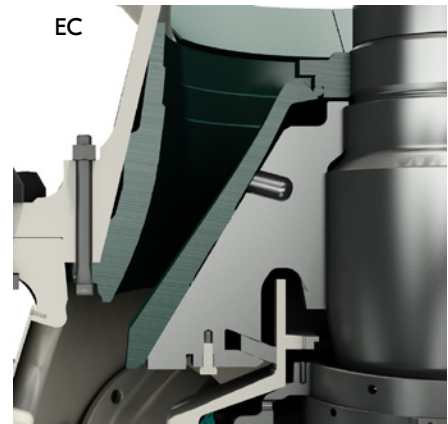

GP11M EC, GP200 EC, GP220 EC, GP300 EC, GP330 EC, GP550 EC

| GP Fine | Difficult and abrasive rock | Difficult and non abrasive rock | Medium and abrasive rock | Medium and non abrasive rock | Easy and abrasive rock | Easy and non abrasive rock |
|---------------|-----------------------------|---------------------------------|--------------------------|------------------------------|------------------------|----------------------------|
| XT510 / XT610 | | | | ●●● | ●● | ●●● |
| XT710 | ●●● | ●●● | ●●● | ●●● | ●●● | ●●● |
| XT720 / XT810 | ●●●* | ●●* | ●●●* | | ●●* | |

● Can be used ●● Good choice ●●● Recommended

*coarse feed

Definitions for different rock types are presented in Wear and materials application guide, page 4.

Maximum feed size and setting ranges min-max, mm (in)

| | GP100 | | | | | GP11F | | | | GP11M | | | GP200 | | | |
|------------------------|---------------------|---------------------|----------------------|----------------------|----------------------|---------------------|----------------------|----------------------|----------------------|----------------------|----------------------|----------------------|------------------------|------------------------|------------------------|----------------------|
| | EF | F | MF | M | C | EF | F | M | C | C | EC | ECLS | EF | F | M | EC |
| Max Feed size | 32 (1.26) | 46 (1.81) | 87 (3.43) | 133 (5.24) | 135 (5.31) | 35 (1.38) | 70 (2.76) | 113 (4.45) | 152 (5.98) | 112 (4.41) | 194 (7.64) | 206 (8.11) | 35 (1.38) | 64 (2.52) | 104 (4.09) | 168 (6.61) |
| 16 mm (0.63 in) stroke | 5-18 (0.20-0.71) | 5-17 (0.20-0.67) | 7-20 (0.28-0.79) | 10-20 (0.39-0.79) | 13-24 (0.51-0.94) | | | | | | | | | | | |
| 18 mm (0.71 in) stroke | | | | | | | | | | | | | 8-27 (0.31-1.06) | 7-29 (0.28-1.14) | 10-29 (0.39-1.14) | 12-35 (0.47-1.38) |
| 20 mm (0.79 in) stroke | 6-16 (0.24-0.63) | 6-15 (0.24-0.59) | 9-18 (0.35-0.71) | 11-18 (0.43-0.71) | 15-22 (0.59-0.87) | 5-23 (0.20-0.91) | 7-24 (0.28-0.94) | 14-28 (0.55-1.10) | 15-29 (0.59-1.14) | 15-29 (0.59-1.14) | 18-32 (0.71-1.26) | 20-51 (0.79-2.01) | | | | |
| 25 mm (0.98 in) stroke | 7-14 (0.28-0.55) | 7-12 (0.28-0.47) | 11-15 (0.43-0.59) | 12-15 (0.47-0.59) | 17-19 (0.67-0.75) | 7-21 (0.28-0.83) | 9-21 (0.35-0.83) | 16-26 (0.63-1.02) | 17-27 (0.67-1.06) | 17-27 (0.67-1.06) | 20-30 (0.79-1.18) | 25-49 (0.98-1.93) | 11-24 (0.43-0.94) | 10-26 (0.39-1.02) | 13-26 (0.51-1.02) | 17-32 (0.67-1.26) |
| 28 mm (1.10 in) stroke | | | | | | | | | | | | | 12.5-22 (0.49-0.87) | 11.5-24 (0.45-0.94) | 14-24 (0.55-0.94) | 20-30 (0.79-1.18) |
| 30 mm (1.18 in) stroke | | | | | | 9-18 (0.35-0.71) | 11-19 (0.43-0.75) | 18-23 (0.71-0.91) | 19-24 (0.75-0.94) | 19-24 (0.75-0.94) | 22-27 (0.87-1.06) | 30-46 (1.18-1.81) | | | | |
| 32 mm (1.26 in) stroke | | | | | | | | | | | | | 14-20 (0.55-0.79) | 13-22 (0.51-0.87) | 15-22 (0.59-0.87) | 24-28 (0.94-1.10) |
| 36 mm (1.42 in) stroke | | | | | | | | | | | | | 15.5-18 (0.61-0.71) | 14.5-20 (0.57-0.79) | 16.5-20 (0.65-0.79) | |

| | GP220 | | | | | | GP300 | | | | | | |
|------------------------|----------------------|----------------------|----------------------|----------------------|----------------------|----------------------|----------------------|----------------------|------------------------|----------------------|----------------------|------------------------|------------------------|
| | EF | F | MF | M | C | EC | EC-LS | EF | F | MF | M | C | EC |
| Max Feed size | 35 (1.38) | 70 (2.76) | 83 (3.27) | 106 (4.17) | 168 (6.61) | 204 (8.03) | 204 (8.03) | 32 (1.26) | 50 (1.97) | 106 (4.17) | 126 (4.96) | 150 (5.90) | 192 (7.56) |
| 18 mm (0.71 in) stroke | 4-30 (0.16-1.18) | 5-32 (0.20-1.26) | 5-31 (0.20-1.22) | 6-32 (0.24-1.26) | 8-37 (0.31-1.46) | 9-42 (0.35-1.65) | 13-52 (0.51-2.05) | | | | | | |
| 25 mm (0.98 in) stroke | 5-27 (0.20-1.06) | 7-28 (0.28-1.10) | 8-27 (0.31-1.06) | 8-28 (0.31-1.10) | 11-33 (0.43-1.30) | 13-39 (0.51-1.54) | 17-49 (0.67-1.93) | 6-22 (0.24-0.87) | 8-28 (0.31-1.10) | 13-24 (0.51-0.94) | 15-29 (0.59-1.14) | 18-32 (0.71-1.26) | 22-41 (0.87-1.61) |
| 28 mm (1.10 in) stroke | 7-25 (0.28-0.98) | 8-27 (0.31-1.06) | 9-25 (0.35-0.98) | 10-27 (0.39-1.06) | 13-31 (0.51-1.22) | 15-37 (0.59-1.46) | 19-47 (0.75-1.85) | 7-21 (0.28-0.83) | 9.5-27 (0.37-1.06) | 14-23 (0.55-0.91) | 16-28 (0.63-1.10) | 19.5-31 (0.77-1.22) | 23.5-39 (0.93-1.54) |
| 32 mm (1.26 in) stroke | 8-23 (0.31-0.91) | 9-25 (0.35-0.98) | 10-23 (0.39-0.91) | 11-25 (0.43-0.98) | 14-29 (0.55-1.14) | 18-35 (0.71-1.38) | 22-45 (0.87-1.77) | 8-19 (0.31-0.75) | 11-25 (0.43-0.98) | 15-21 (0.59-0.83) | 17-26 (0.67-1.02) | 21-29 (0.83-1.14) | 26-37 (1.02-1.46) |
| 36 mm (1.42 in) stroke | 10-21 (0.39-0.83) | 11-23 (0.43-0.91) | 11-21 (0.43-0.83) | 12-23 (0.47-0.91) | 16-27 (0.63-1.06) | 20-33 (0.79-1.30) | 23-43 (0.91-1.69) | 9-17 (0.35-0.67) | 12.5-23 (0.49-0.91) | 16-19 (0.63-0.75) | 18-24 (0.71-0.94) | 22.5-27 (0.89-1.06) | 28-35 (1.10-1.38) |
| 40 mm (1.57 in) stroke | 11-19 (0.43-0.75) | 12-21 (0.47-0.83) | 13-19 (0.51-0.75) | 14-21 (0.55-0.83) | 17-25 (0.67-0.98) | 21-31 (0.83-1.22) | 25-41 (0.98-1.61) | 10-15 (0.39-0.59) | 14-21 (0.55-0.83) | | 19-22 (0.75-0.87) | 24-25 (0.94-0.98) | 30-33 (1.18-1.30) |

| | GP330 | | | | | | GP550 | | | | | |
|------------------------|----------------------|----------------------|----------------------|----------------------|----------------------|----------------------|----------------------|----------------------|------------------------|----------------------|------------------------|------------------------|
| | F | MF | M | C | EC | EC-TR | EF | F | MF | M | C | EC |
| Max Feed size | 72 (2.83) | 93 (3.66) | 129 (5.08) | 174 (6.85) | 215 (8.46) | 215 (8.46) | 50 (1.97) | 73 (2.87) | 94 (3.70) | 137 (5.39) | 177 (6.97) | 235 (9.25) |
| 18 mm (0.71 in) stroke | 5-31 (0.20-1.22) | 6-31 (0.24-1.22) | 7-37 (0.28-1.46) | 8-42 (0.31-1.65) | 10-49 (0.39-1.93) | 10-68 (0.39-2.68) | | | | | | |
| 22 mm (0.87 in) stroke | 6-29 (0.24-1.14) | 7-29 (0.28-1.14) | 8-36 (0.31-1.42) | 9-41 (0.35-1.61) | 11-48 (0.43-1.89) | 11-67 (0.43-2.64) | | | | | | |
| 25 mm (0.98 in) stroke | | 8-28 (0.31-1.10) | 9-35 (0.35-1.38) | 10-39 (0.39-1.54) | 12-46 (0.47-1.81) | 12-65 (0.47-2.56) | 8-29 (0.31-1.14) | 11-35 (0.43-1.38) | 12-38 (0.47-1.50) | 16-41 (0.63-1.61) | 18-43 (0.71-1.69) | 22-46 (0.87-1.81) |
| 28 mm (1.10 in) stroke | 8-27 (0.31-1.06) | 9-27 (0.35-1.06) | 10-33 (0.39-1.30) | 11-38 (0.43-1.50) | 13-45 (0.51-1.77) | 13-64 (0.51-2.52) | 9-28 (0.35-1.10) | 12-34 (0.47-1.34) | 13.5-37 (0.53-1.46) | 18-40 (0.71-1.57) | 20-41 (0.79-1.61) | 23.5-45 (0.93-1.77) |
| 32 mm (1.26 in) stroke | 9-25 (0.35-0.98) | 10-25 (0.39-0.98) | 11-31 (0.43-1.22) | 12-36 (0.47-1.42) | 14-43 (0.55-1.69) | 14-62 (0.55-2.44) | 10-26 (0.39-1.02) | 13-32 (0.51-1.26) | 15-35 (0.59-1.38) | 20-38 (0.79-1.50) | 22-39 (0.87-1.54) | 25-43 (0.98-1.69) |
| 36 mm (1.42 in) stroke | 10-23 (0.39-0.91) | 11-23 (0.43-0.91) | 12-29 (0.47-1.14) | 13-34 (0.51-1.34) | 15-41 (0.59-1.61) | 15-60 (0.59-2.36) | 11-24 (0.43-0.94) | 14-29 (0.55-1.14) | 16.5-32 (0.65-1.26) | 22-35 (0.87-1.38) | 23.5-37 (0.93-1.46) | 26.5-41 (1.04-1.61) |
| 40 mm (1.57 in) stroke | 11-20 (0.43-0.79) | 12-20 (0.47-0.79) | 13-27 (0.51-1.06) | 14-32 (0.55-1.26) | 16-38 (0.63-1.50) | 16-58 (0.63-2.28) | 12-22 (0.47-0.87) | 15-26 (0.59-1.02) | 18-29 (0.71-1.14) | 24-32 (0.94-1.26) | 25-35 (0.98-1.38) | 28-39 (1.10-1.54) |

EF = Extra fine
C = Coarse

F = Fine
EC = Extra coarse

MF = Medium fine
ECLS = Extra coarse large setting

M = Medium
ECTR = Extra coarse - tramp release

The minimum setting is limited by either the power requirement or adjusting pressure. Depending on rock characteristics, the minimum closed side setting can change.



When to change liners

Liners must be changed before they are worn through in order to prevent damage to frame or head. Liners should be changed no later than when the A dimension is 10-15 mm depending on crusher model.

Production aspects may sometimes favour changing of wear parts before they are fully utilized. Hourly capacity or product quality may decrease towards the end of liner lifetime and it may be economical to change the liner before the end of its lifetime.

A distorted wear profile typically causes a reduction in capacity. Other symptoms of distorted wear profiles are high power and pressure and short lifetime of wear parts. A distorted wear profile may lead to liners having to be replaced before they are fully worn.

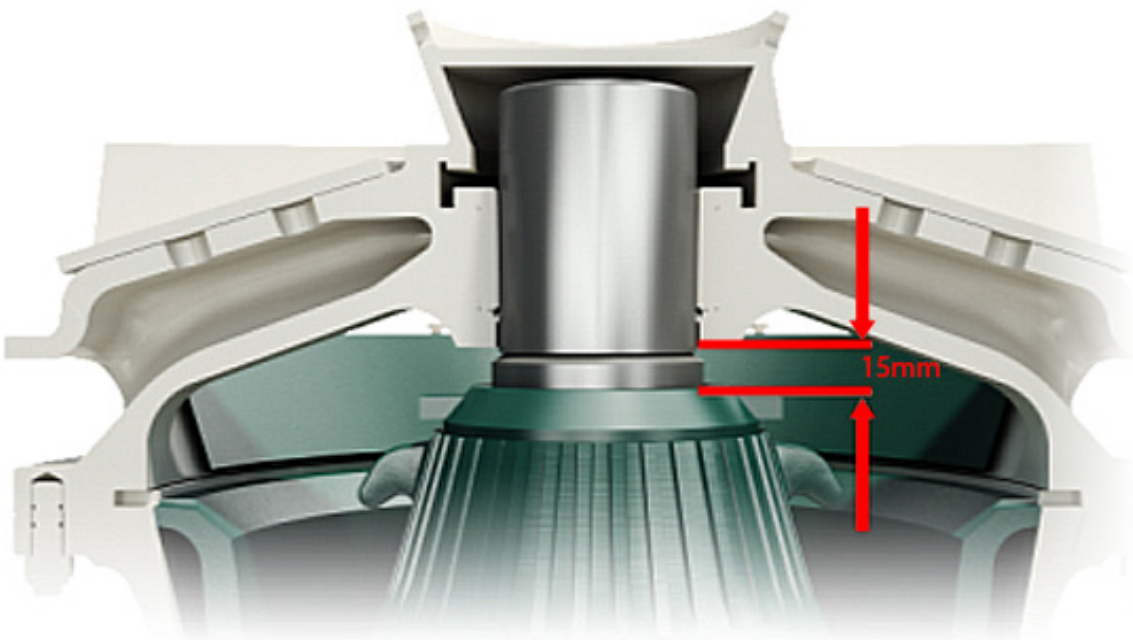

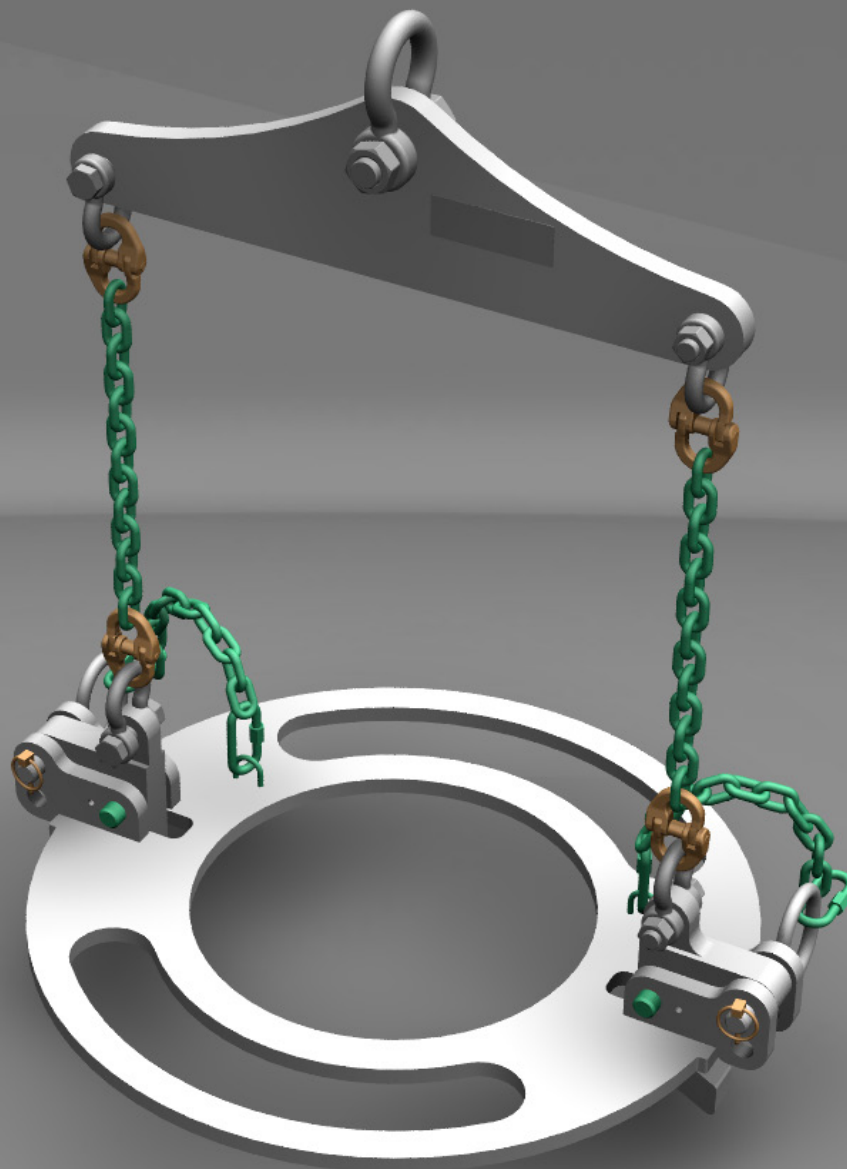

Mantle lifting tools

Our crusher wear part lifting tools are designed with OEM expertise, making them the best choice to remove mantles from your Metso Outotec crushers.

Efficient crusher maintenance

Specially designed, fit-for-purpose tools makes wear part change-outs faster and more efficient. By using OEM parts, risk of damaging equipment is avoided. As a result, maintenance times are shortened and crusher downtime is reduced.

Improved safety and quality

To succeed in today's competitive environment, aggregate producers often seek to optimize their crusher maintenance. Using parts that last longer and make crusher maintenance easier and safer can make the big difference. Metso Outotec's specialty tools are developed with quality suppliers ensuring that high standards and tolerances are met.



| TOOLS | APPLICATIONS | LOAD LIMIT |
|-------------------------|---------------------------------|------------|
| Mantle lifting tools | GP220 | 2500 KG |
| | GP330 | 3500 KG |
| | GP550 (excluding the EF mantle) | 6500 KG |
| | GP7 | 14500 KG |

Benefits

- OEM design and assurance
- Improved safety and maintenance
- Reduced downtime with more efficient changeouts

Read more at:
mogroup.com/CrusherParts





Metso Outotec is a frontrunner in sustainable technologies, end-to-end solutions and services for the aggregates, minerals processing and metals refining industries globally. By improving our customers' energy and water efficiency, increasing their productivity, and reducing environmental risks with our product and process expertise, we are the **partner for positive change**.

Metso:Outotec

Metso Outotec, Töölönlahdenkatu 2, FI-00100, Helsinki, Finland.
tel. +358 20 484 100, fax +358 20 484 101
mogroup.com