

# Metso:Outotec

Designed to perform

## Select™ horizontal grinding mills



Redefining simplicity



Exceeding efficiency

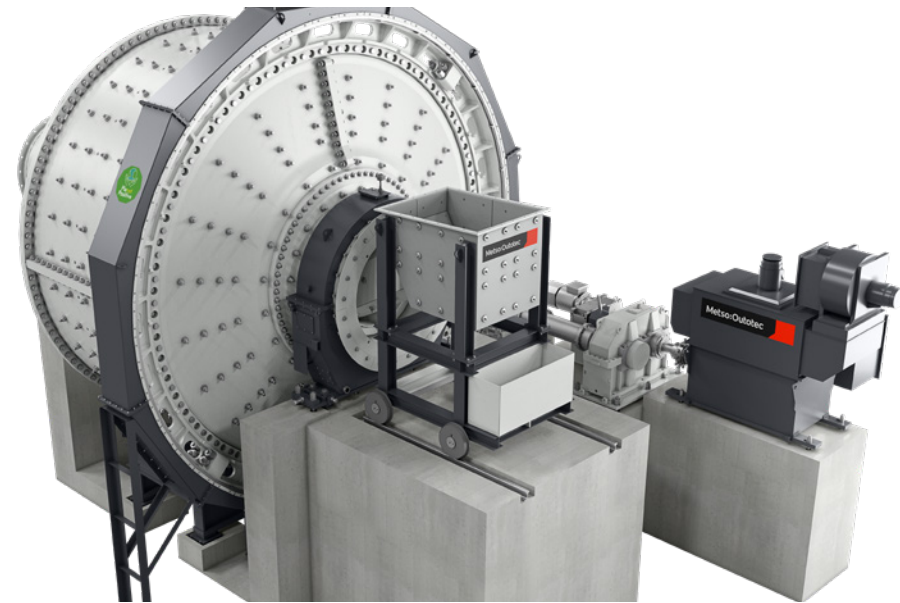

Metso Outotec advances an unrivaled innovation legacy by introducing the Select™ horizontal grinding mills. Though the product line is unique, it combines our extensive experience and expertise with our unmatched design capabilities, which allow customers to exceed their operational goals. Our ease of maintenance and reduced downtime results in a more available, reliable and productive mill.

### Simplicity without compromising quality

Let Metso Outotec take the complications out of your operations. With our new innovation, we have thoroughly redefined selection with our simplified process.

Pre-engineered mill designs can either be specified by a customer, or chosen by the Metso Outotec Process team, after reviewing the application. Next, in the quoting phase, a total proposal package containing a complete offering is provided for review. This offering includes datasheets, general arrangement drawings, foundation drawings, P&ID drawings, standard shipping information as well as manufacturing locations — all in addition to a standard proposal. After an order is placed, standard updates on the equipment status is always communicated. The Select™ horizontal grinding mills are delivered efficiently, and on time — just as Metso Outotec promises.

### Superior performance

The efficiency of your process equipment is a critical factor in maximizing your operation. Our Select™ horizontal grinding mills world-class performance is the result of mindful component selection and vast design expertise.

Not only do we lead our industry, but we learn from our history. With over a century of experience, Metso Outotec experts have proven their industry know-how with the design of the Select™ horizontal grinding mill and its unrivaled performance. Due to the robust design and components, the Select™ horizontal grinding mills are exceedingly reliable and capable of handling virtually any application.

### Benefits of our pre-engineered solutions

The cost of running an operation can increase at an alarming rate. Thankfully, Metso Outotec has invested in pre-engineered solutions, which allows for a reduction in project costs. In addition to that, the time required for equipment selection and delivery is also reduced (due to the use of standardized equipment selection, quotation preparation and order execution.) With developing a pre-engineered package, a lot of the time and costs that are usually spent in the engineering and selection stages are then eliminated. This results in faster mill deliveries as well.

At Metso Outotec, it is our core expertise to help our customers transform their operation whilst transforming the industry. With our innovative robust design, your operation will be up and running with high efficiency and high productivity, allowing you the opportunity to exceed your operational goals today and tomorrow. With an increase in throughput comes an increase in profit and power — what could this do for your operation?

### Select support

Metso Outotec has a complete portfolio of mill reline equipment, lining systems, parts and services that make us your one-stop-shop for each of your operational needs. With our service, you can ensure your mill is consistently running at optimal levels to further enhance your production.

Read more at  
[mogroup.com/select-mills](http://mogroup.com/select-mills)

Select™ mills

# Select range and components

Take advantage of Metso Outotec's experience and expertise with our pre-engineered designs. Get your operation up and running with our simple selection and order process that leads to quicker deliveries.

Mill type (models)	Diameter	EGL length	Installed power
SAG (31)	3,80 m - 9,00 m	1,90 m EGL - 4,50 m EGL	400 kW - 7.800 kW
Ball (41)	0,60 m - 6,00 m	0,90 m EGL - 12,00 m EGL	2,2 kW - 7.800 kW
Rod (8)	2,40 - 4,60	3,60 m EGL - 6,10 m EGL	200 kW - 1.600 kW

Select scope
Rotating mill structure
Start-up set of lining
Induction drivetrain

Select tools
Jacking cradles
Jacking system
Hydraulic torque wrenches
UT bolt tension measuring system

Select additions
Feed chute/spout
Discharge trommel

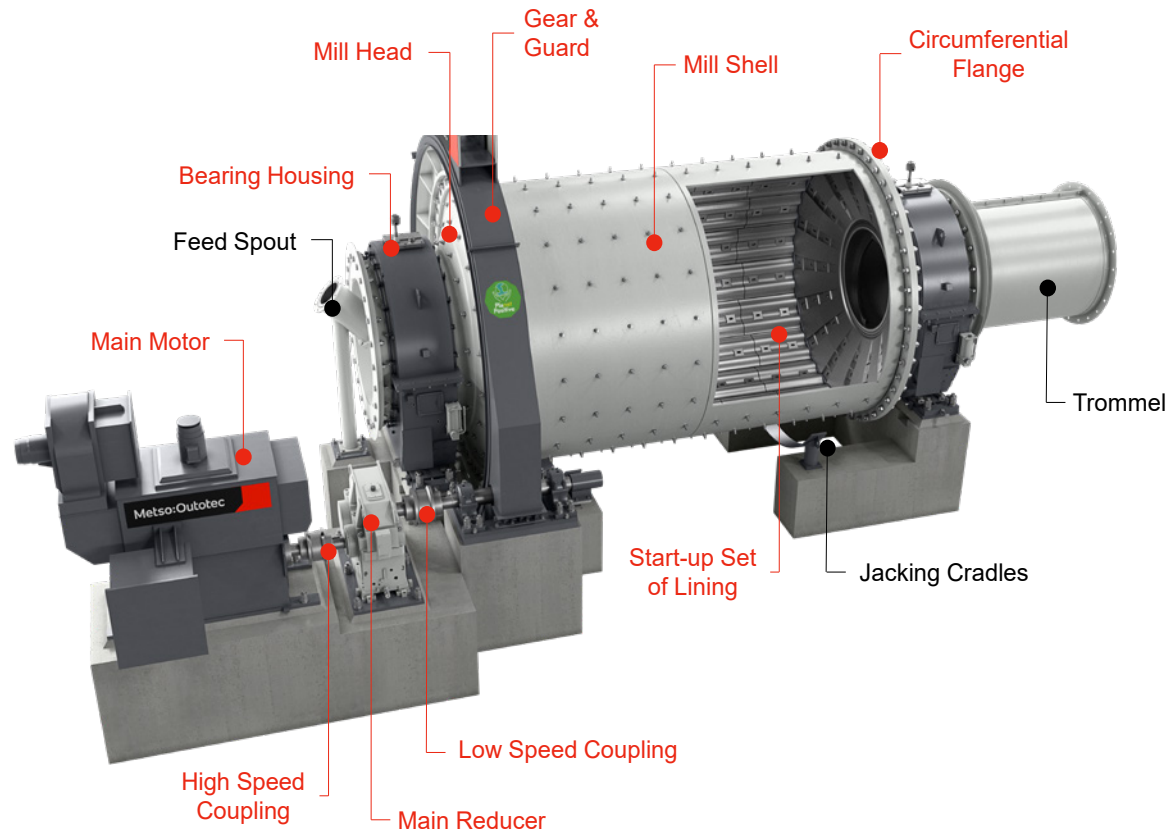

Have questions? Contact us today at [mogroup.com/contact](https://mogroup.com/contact)