

Metso

Grinding auxiliary equipment

Select™ Ball Feeder

Optimizing mill performance



The standard Select™ Ball Feeder is designed for all applications using steel ball grinding media.

Simple and robust

The hopper outlet discharges onto a cleated belt conveyor to feed the grinding media.

The mining duty conveyor is the only moving part of the feeder, consisting of:

- Heavy duty cleated belt
- High efficiency motorized pulley with integral helical gearbox
- Heavy duty idler pullies

The conveyor is of a standard design, with spare parts that are interchangeable between all Select™ Ball Feeder sizes.

Easy to operate and accurate

Changes in the mill process parameters require variations to the media feed rate. The Select™ Ball Feeder is easily adjustable and can be changed from the operator control desk.

Small environmental footprint

The small conveyor motor and the intermittent operation uses only ~60 kWh per year (150 mm balls fed at 1600 kg/h).

Feeder design

The hopper is a welded steel bin that rests on three load cells. The load cells sit on a welded steel structure that is bolted to the plant floor. The hopper is lined with bolt on Trellex PP steel reinforced rubber lining sheets to reduce wear, vibrations, and noise.

A conveyor is mounted below the hopper and is equipped with a motorized pulley belt conveyor drive, support/return rollers, and a reinforced rubber belt with cleats. The cleats deliver a volume of balls according to the control system set points.

When in Run mode, the motorized pulley belt conveyor drive is started via a user adjusted timer. A rotation sensor detects rotation of the return pulley and provides pulses to confirm belt movement. The conveyor stops when a user defined set number of pulses are received.

The Select™ Ball Feeder is provided with a local junction box to connected to the plant PCS/DCS.

Read more at metso.com/portfolio/ball-feeder

Select™ Ball Feeder reaches its full potential when bundled with Metso Advanced Process Control and is fully automated.

Benefits

- Continuous and safe charging of grinding media
- Automatic grinding media consumption calculation and optimized mill efficiency
- Connection to either plant PCS/DCS or to the Metso Mill Control System with standard interface options

Standard Select™ Ball Feeders

The standard Select™ Ball Feeder is designed for all applications using steel ball grinding media.

	Select™ 10 Metric Ton Ball Feeder	Select™ 20 Metric Ton Ball Feeder	Select™ 40 Metric Ton Ball Feeder
Technical specifications			
Hopper capacity	10 tons	20 tons	40 tons
Design feed capacity ^[1]	400 kg/h	800 kg/h	1,600 kg/h
Media size	20 mm to 150 mm		
Hopper lining thickness (side/bottom)	13/15 mm	15/25 mm	25/40 mm
Conveyor W x L	700 x 680		
Operating temperature	-20 to +40 °C		
Installed power	1.1 kW		
Panel rating	IP66 / NEMA 4X		
Instrument ratings	IP67		
Instrument & control voltage	24 VDC		
Motor enclosure	IP66		
[1] The maximum feed capacity is not restricted by machinery, but represents a 24 hours refill rate			

Optional ball loading equipment:

- Select™ Ball Hopper
- Select™ Ball Transporter

Select™ 10 mTon Ball Feeder



Select™ 20 mTon Ball Feeder



Select™ 40 mTon Ball Feeder

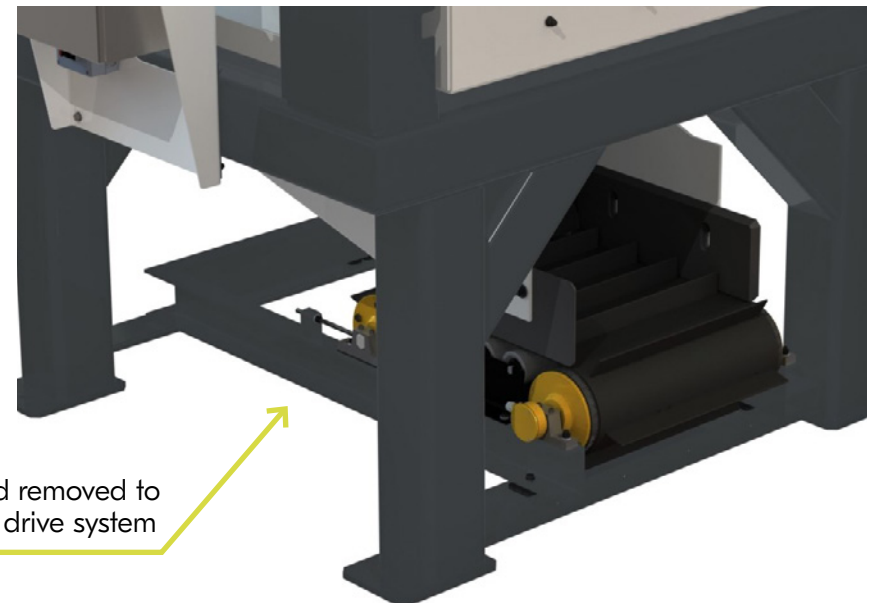

Guard removed to show drive system

Optional ball loading equipment

Select™ Ball Feeder belt assembly (including motor)

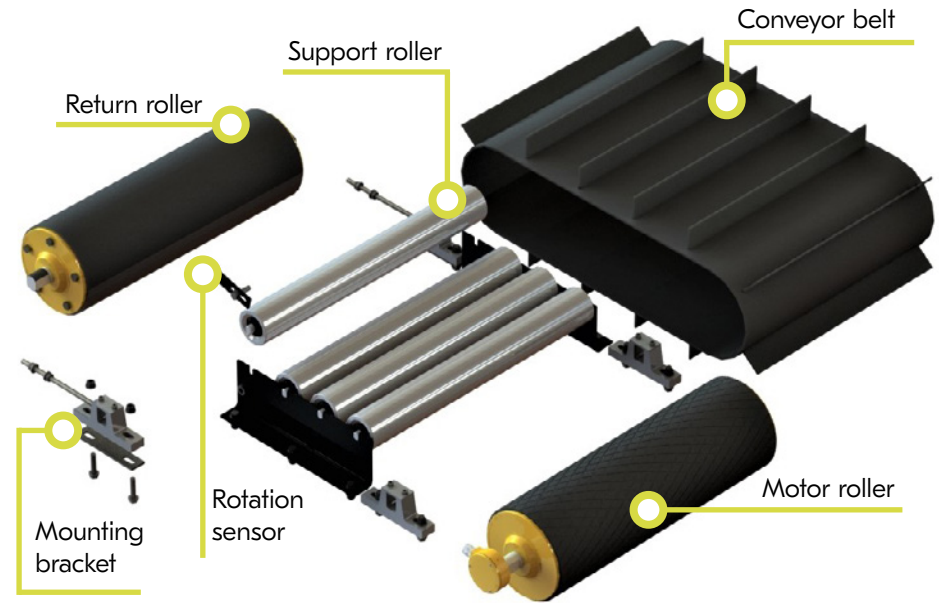

Select™ Ball Hopper (shown with bulk bag / super sack splitting mechanism)

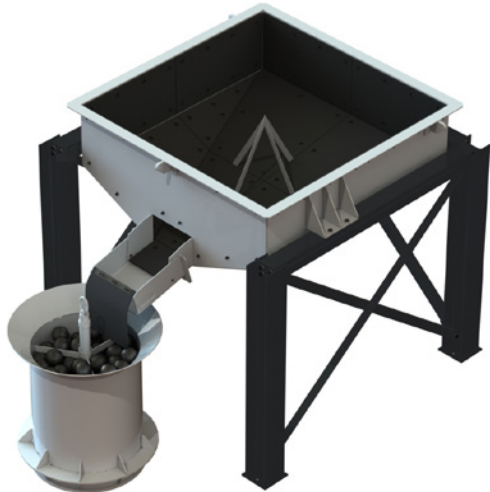

Select™ Ball transporter

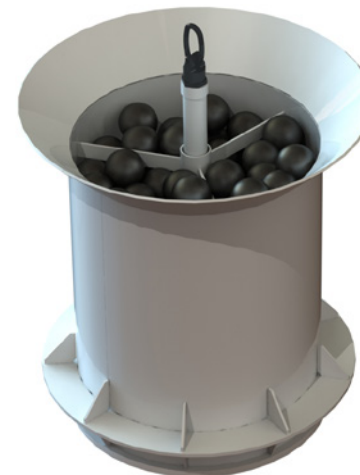

Metso is a frontrunner in sustainable technologies, end-to-end solutions and services for the aggregates, minerals processing and metals refining industries globally. We improve our customers' energy and water efficiency, increase their productivity, and reduce environmental risks with our product and service expertise. We are the **partner for positive change**.